

Suspension/Wheels

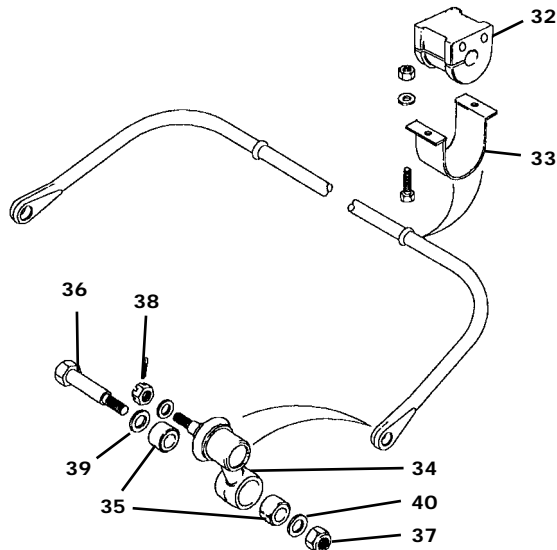

Range Rover Classic shown with "Sports RNW212" wheels.

Wheel Nuts For Alloy Wheels



- RNX041 Through 1992 \$ 10.75ea
- RNX043 Stainless Steel capped 1993 on \$ 11.75ea

For Optional Steel Wheels

- RNS066 For Steel wheel nuts \$ 4.50ea



Locking Wheel Nut Set

- RNW217 4 Alloy, 1 steel \$ 112.00
- RNW219 5 Alloy \$ 115.00
- RNW221 5 Steel \$ 119.00

Range Rover Classic ARB Locker

- | | | | |
|---------|---------------------------------|--------------------------------|------------|
| RD03 | Range Rover Classic | up to 1992 | \$ 699.00 |
| | Range Rover Classic | 1993 (please provide axle No.) | |
| RD56 | Range Rover Classic | 1994 on | \$ 699.00 |
| ARB1118 | Complete Rear ARB Kit* | up to 1992 | \$ 999.00 |
| ARB1113 | Complete Rear ARB Kit* | 1994 on | \$ 1030.00 |
| ARB1128 | Complete Front & Rear ARB Kits* | up to 1992 | \$ 1790.00 |
| ARB1114 | Complete Front & Rear ARB Kits* | 1994 on | \$ 1823.00 |

Discovery ARB Locker

- | | | | |
|---------|---------------------------------|---------|------------|
| RD56 | Discovery I | 1994 on | \$ 699.00 |
| ARB1117 | Complete Rear ARB Kit* | 1994 on | \$ 1029.00 |
| ARB1127 | Complete Front & Rear ARB Kits* | 1994 on | \$ 1819.00 |

ARB Accessories

- RDCK Air Compressor Kit \$ 235.00
- PUK Inflation kit \$ 42.00

*(Kits includes all necessary Genuine bearings, gaskets and hardware, for a complete conversion)

Deep Dish
RNW215
\$287.15ea.



Tornado
RNW211
\$295.00ea.



Castor
RNW213
\$289.00ea.



Styled
RNW214
\$369.00ea.



Sports
RNW212
\$369.00ea.



Vented Steel
RNW216
\$77.45ea.



Lug Nut Wrench

- LUG1116 Ultra heavy duty lug nut wrench \$ 16.00

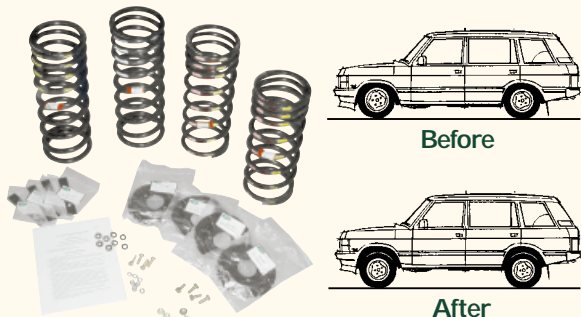

Genuine Coil Conversion for LWB Air Suspension

Tired of losing sleep over your collapsed air suspension? Land Rover designed and built into the Range Rover Classic LWB a fantastic air suspension system that was way ahead of it's time. However, when a malfunctioning component needs repair or replacement, it can get expensive and time consuming fast. Do away with all the air suspension hassle and expense by converting your Range Rover Classic LWB to a Land Rover Genuine Parts-equipped coil sprung Range Rover. This kit contains everything for the proper conversion and continued reliable on or off-road performance. Includes detailed instructions. Also available as an OME kit RNK5105A.

- RNK5105 Coil Spring Conversion Kit**
Range Rover Classic LWB \$ 345.00

Genuine Suspension Bushing Kits

Includes: all Land Rover Genuine Parts bushings and hardware for replacing suspension bushings on coil sprung vehicles.

- RNK5910 Front Suspension Pre '86 Range Rover \$ 165.00
- RNK5911 Rear Suspension Pre '86 Range Rover \$ 193.00
- RNK5912 Front Suspension 86-90 Range Rover \$ 115.00
- RNK5913 Rear Suspension 86-92 Range Rover \$ 165.00
- RNK5914 Front Suspension 91 > Range Rover \$ 119.00
- RNK5915 Rear Suspension 93 > Range Rover \$ 175.00
- RNK5918 Front Suspension Discovery I \$ 119.00
- RNK5915 Rear Suspension Discovery I \$ 175.00

Plastic wheel center caps sold separately. Please inquire.

for fast service 800 403-7591



802 879-0032



FAX 24 Hours (802) 879-9152 • www.roversnorth.com • Hours: Mon-Fri 8:00-5:30; Sat 8:30-12:30 EST