

I would like to thank you and all the staff at Rovers North for excellent technical support and service that has been provided to me over the years. I have received nothing but the best service and advice from the staff at Rovers North. Your knowledge of the Land Rovers and your commitment to your customers are apparent.

*U. Thaker, M.D.,
Pennsylvania*

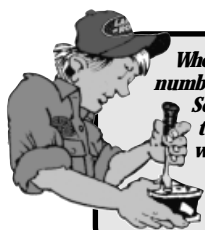
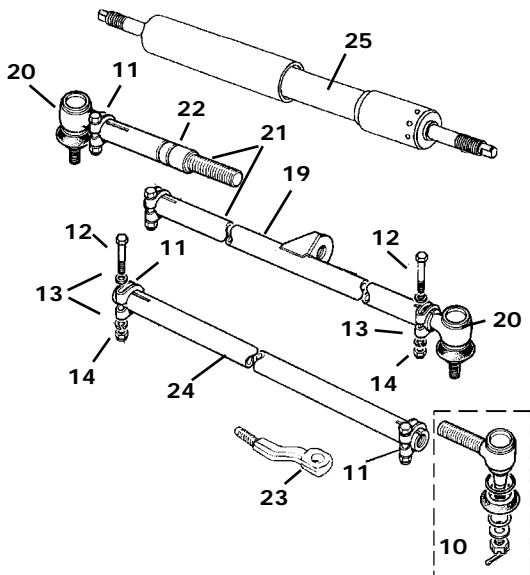
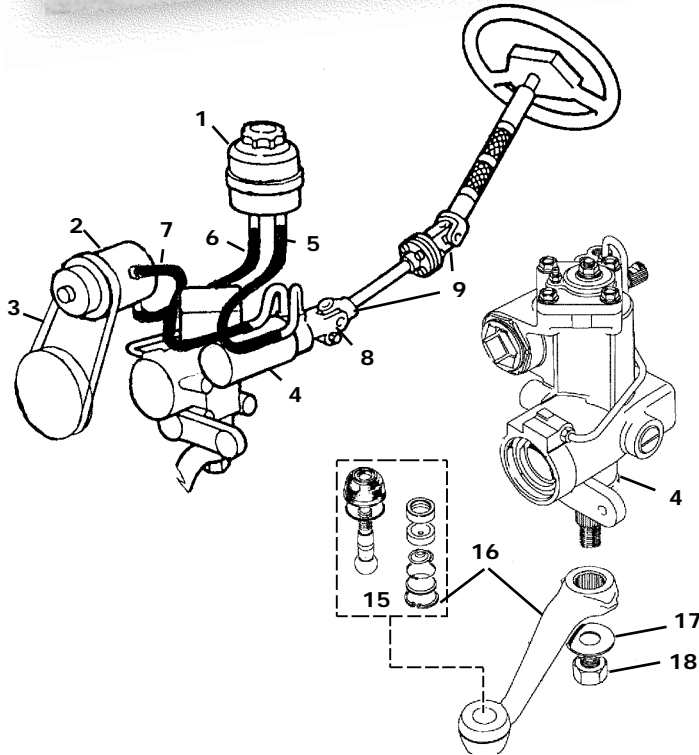

When replacing a steering ball joint, count the number of turns required to remove the old ball joint. Screw the new ball joint in the same number of turns as that of the one removed. This technique will keep the steering alignment relatively close and speed up the wheel and steering wheel alignment process. Also, this is one of those Land Rover maintenance procedures that calls for plenty of anti-seize compound during installation.

Power Steering System

Range Rover Classic / Discovery I

1.	RNS001	Reservoir - All Models		\$ 25.50
2.	RNS002	Pump Assembly Range Rover	'87-'92	\$ 319.00
	RNS003	Range Rover	'93 on	\$ 595.00
	RNS003	Discovery I		\$ 595.00
3.	RNC004	Power Steering Belt Range Rover	'87-'94	\$ 12.95
4.	RNS004	New Steering Box - All Models		\$ 498.00
	RNS111	Rebuilt Steering Box - All Models		\$ 257.75
		Core charge (new & rebuilt)		\$ 250.00
5.		Hose, Steering Box to Reservoir		
	RNS007	Range Rover (up to NA610839)	'87	\$ 24.50
	RNS006	Range Rover (from NA610840)	'87-'95	\$ 29.50
	RNS013	Discovery I		\$ 25.75
	RNS011	O-Ring for all Res. to Box Hoses		\$ 1.75
6.		Hose, Reservoir to Pump		
	RNS005	Range Rover	'87-'95	\$ 49.00
	RNS012	Discovery I		\$ 47.50
7.		Hose, Pump to Box Range Rover Classic		
		Coil Suspension;		
	RNS008			\$ 76.95
		Air Suspension;		
	RNS018	Hose Pump End		\$ 48.50
	RNS019	Hose at Box End		\$ 44.40
	RNS020	RR '95 and Discovery I		\$ 33.75
	RNS009	O-Ring for all Pump to Box Hoses		\$ 1.75
8.		U-Joint, for Steering Shaft		
	RNS017	Range Rover (up to MA601606)		\$ 49.50
	RNS010	Range Rover (from MA601606)	thru '94	\$ 57.50
	RNS021	Range Rover '95 & Discovery I U-joint only		\$ 134.00
9.		Steering Shaft, Complete Assembly		
	RNS014	Range Rover	'87-'94	\$ 255.00
	RNS015	Range Rover & Discovery I	'95	\$ 299.00

Track Rod Cross Rod

Range Rover Classic / Discovery I

10.	RNS069	Ball Joint Assembly for Cross Rod	RH Thread	\$ 23.00
	RNS070		LH Thread	\$ 23.00
11.	RNS076	Securing Clamp*		\$ 1.95
12.	RNS073	Bolt for Clamp*		\$.95
13.	RNS074	Flat Washer*		\$.30
14.	RNS075	Nut*		\$.50
15.	RNS084	Ball Joint Repair Kit / Steering Drop Arm		\$ 52.50
16.		Drop Arm for Steering Box		
	RNS080	Range Rover	'87-'91	\$ 127.00
	RNS077	Range Rover & Discovery I	'92-'95	\$ 135.00
17.		Lock Washer Drop Arm		
	RNS078	Range Rover	'87-'91	\$ 2.50
	RNS071	Range Rover & Discovery I	'92-'95	\$ 4.75
18.	RNS083	Nut Steering Drop Arm		\$ 7.00
19.	RNS079	Long Tube		\$ 99.50
20.	RNS069	Ball Joint for Track Rod		\$ 23.00
21.	RNS091	Track Rod Assembly		\$ 238.50
22.	RNS085	Short Tube (Adjuster)		\$ 55.00
23.	RNS088	Eye Cross Rod		\$ 92.50
24.	RNS081	Cross Rod		\$ 27.50
25.	RNS122	Steering Damper/Stabilizer, Land Rover Genuine		\$ 75.00
	OMESD11	Steering Damper/Stabilizer, Old Man Emu		\$ 69.00
	RNA245	Steering Damper/Stabilizer, Bilstein		\$ 85.00
*	RNK553	Clamp Kit tie rod ends (includes * items)		\$ 3.30

for fast service 800 403-7591



802 879-0032



FAX 24 Hours (802) 879-9152 • www.roversnorth.com • Hours: Mon-Fri 8:00-5:30; Sat 8:30-12:30 EST